



FUNDICIONES  
**nardo**

Metales fundidos de **Alta Calidad**

[www.nardo.com.mx](http://www.nardo.com.mx)



## PROCESOS DE FABRICACIÓN

- FORJA
- LAMINADO
- EXTRUSIÓN
- INYECCIÓN
- VACIADO POR GRAVEDAD



FUNDICIONES  
narro

# VACIADO POR GRAVEDAD

- MOLDE PERMANENTE
- CERA PERDIDA
- CASCARA ( SHELL)
- ARENA EN VERDE
- ARENA AUTOFRAGUANTE ( NO-BAKE)
- LOST FOAM



FUNDICIONES  
narrodo

# HISTORIA

- EMPRESA 100 % MEXICANA
- MAS DE 60 AÑOS DE EXPERIENCIA
- FABRICANTE DE PIEZAS DESDE  
2 KG HASTA 3500 KG
- 10 AÑOS DE EXPERIENCIA EN SECTOR

FUNDICIÓN DE TROQUELES



FUNDICIONES  
ricardo

# PROCESOS DE FABRICACION EN FUNDICIONES NARDO

- MOLDEO EN ARENA EN VERDE
- MOLDEO EN ARENA  
AUTOFRAGUANTE
- HORNOS DE INDUCCION
- HORNOS DE CUBILOTE



FUNDICIONES  
nardo

## CONTROLES DE FABRICACION EN FUNDICIONES NARDO

- ESPECTROMETRO
- DETERMINADOR DE CARBONO POR COMBUSTION
- METALOGRAFIA Y DUREZA
- LABORATORIO DE ARENAS
- LIQUIDOS PENETRANTES Y PARTICULAS MAGNETICAS



# FABRICACION DE MODELOS

- MADERA
- ALUMINIO
- RESINAS



FUNDICIONES  
nardo

- ESTIROPORT (UNICEL)

NOTA:

SE CUENTA CON EL SOPORTE PARA FABRICAR VIA "CNC" O DE MANERA

CONVENCIONAL





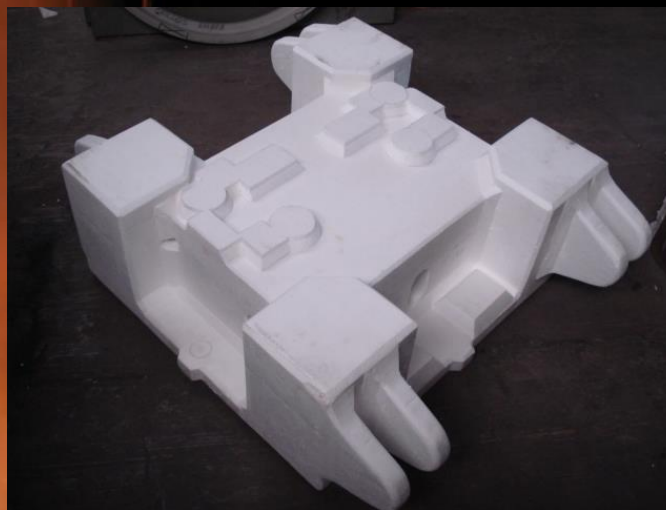

FUNDICIONES  
narro





FUNDICIONES  
ricardo



# EMPRESAS PARA LAS QUE SE HA TRABAJADO

- UNTROMEX
- SHULLER
- GRIMM
- THREMSA
- ALGAIER
- YOROZU
- NUGAR
- PEASA
- BENTELER
- CEA
- GESTAM
- PRUMSA

- VW
- NISSAN
- TOYOTA
- GM
- FEG
- PWO
- FNG
- HIROTEC
- UNIPRESS
- REFAMEX
- CARTEC



FUNDICIONES  
ricardo

# MATERIALES

- HIERRO GRIS DE DIVERSAS CLASES
- HIERRO NODULAR DE DIVERSAS CLASES
- ACEROS AL CARBONO BAJA Y MEDIA



FUNDICIONES  
narro

## ALEACION

- ALUMINIO

## CAPACIDADES

- PIEZAS DE 5 KG HASTA 3500 KG EN HIERRO GRIS
- PIEZAS DE 5 KG HASTA 1500 KG EN HIERRO

NODULAR Y ACERO

- DIMENSIONES MAXIMAS 3.5 MTS X 3.5 MTS X  
1.5 MTS



FUNDICIONES  
nardolo

# INGENIERIA Y DESARROLLO

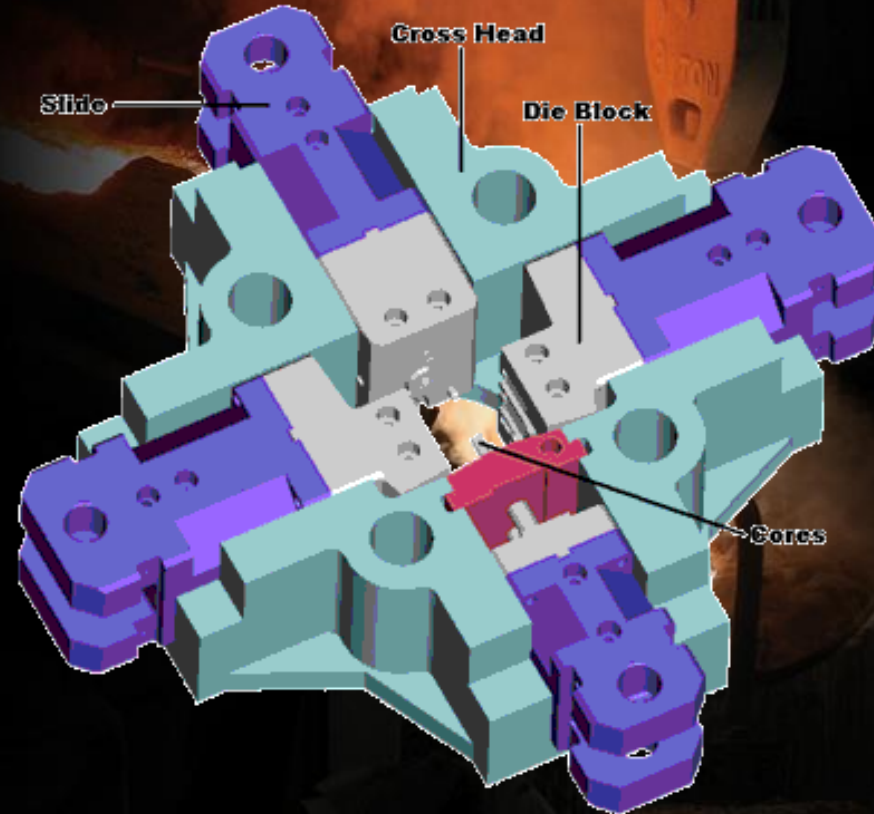

FUNDICIONES  
narrodo

# INGENIERIA APLICADA

C.I. 6893

CLIENTE: UNIROMEX  
 DESCRIPCION: BASE SUP. 104 P

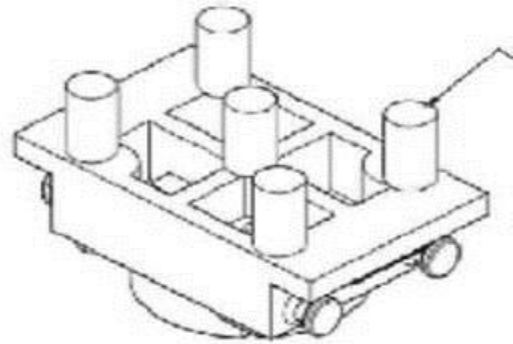

CLIENTE: UNIROMEX  
 DESCRIPCION: BASE INT. 104 P

(5)  
 TUBO DE:  
 # 4" x 6" h

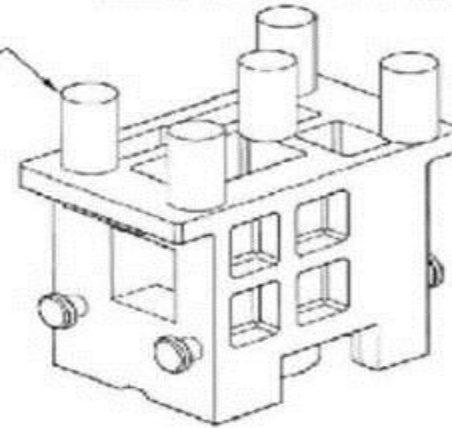

C.I. 6872

CLIENTE: YOROZU  
 DESCRIPCION: TROQUEL 54415

(5)  
 CAMISAS DE:  
 # 4" x 6" h

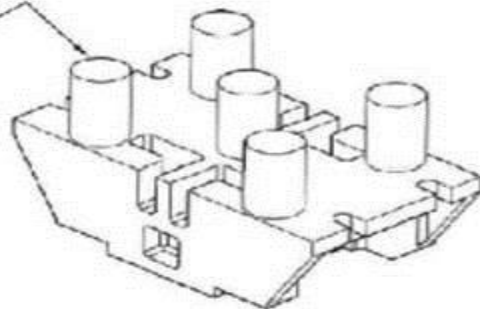

CLIENTE: YOROZU  
 DESCRIPCION: TROQUEL INFERIOR 115160056

(20)  
 CAMISAS DE:  
 #5" x 6" h

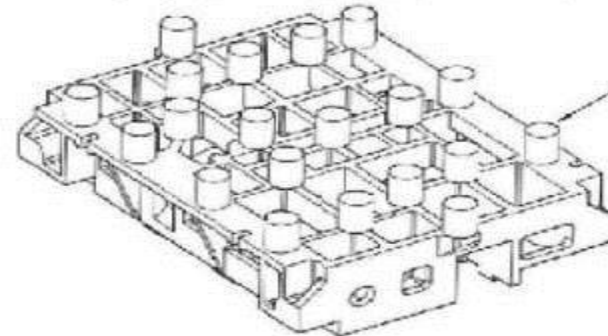

1:1  
 HIERRO GRIS

PESO NETO: 2,710 Kg.  
 PESO BRUTO: 3,090 Kg.

CLIENTE: CARILEG  
 DESCRIPCION: TROQUEL BASE 1721-BMC

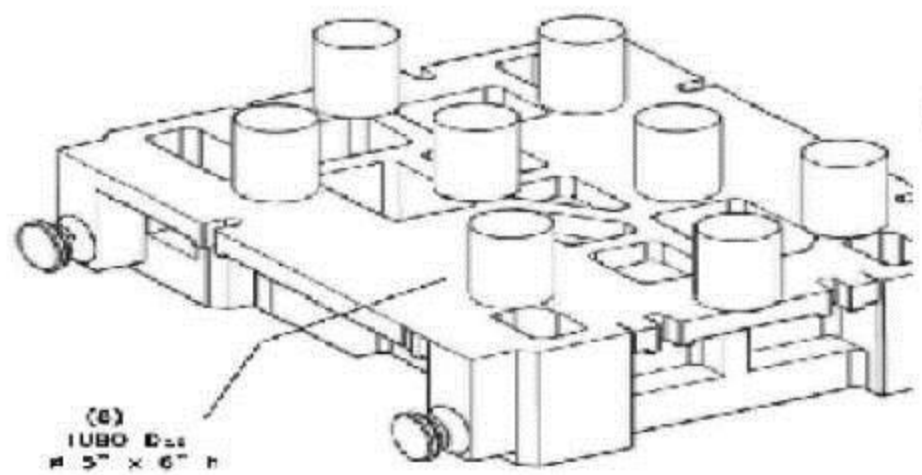

CLIENTE: TRHEMSA  
 DESCRIPCION: FORMADOR INF. 953/954

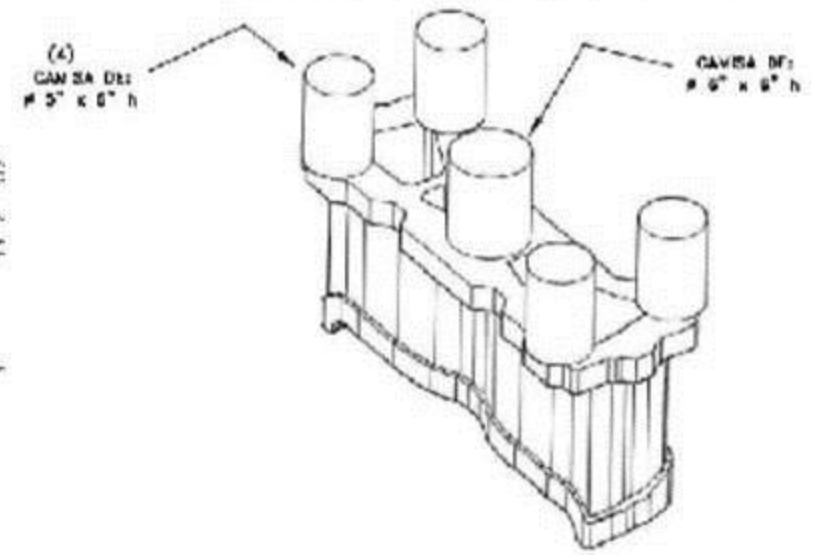

CLIENTE: TRHEMSA  
 DESCRIPCION: PRENSA CHAPA 154 OP-20

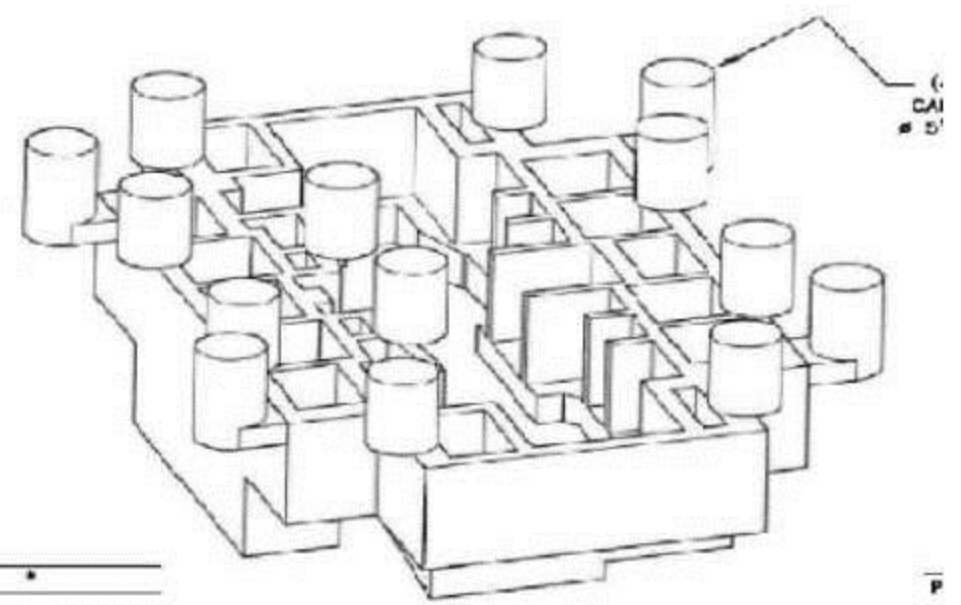

CLIENTE: UNTROMEX  
 DESCRIPCION: BASE INF. 0072

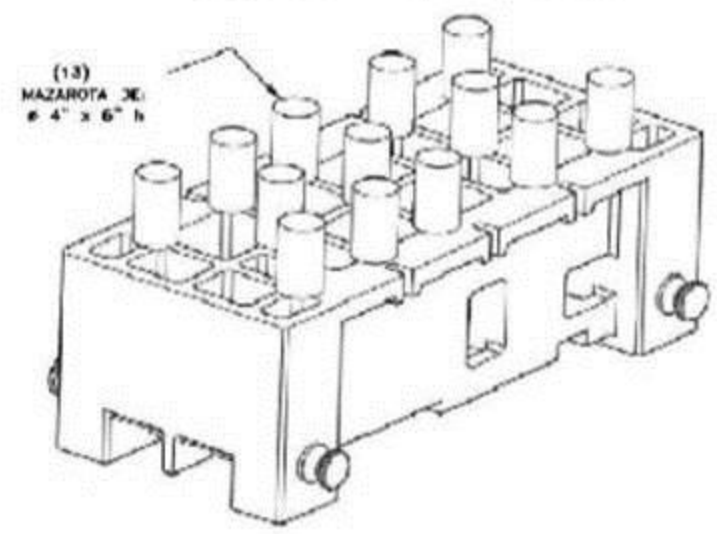



# ANALISIS METALOGRAFICO



FUNDICIONES  
narrodo

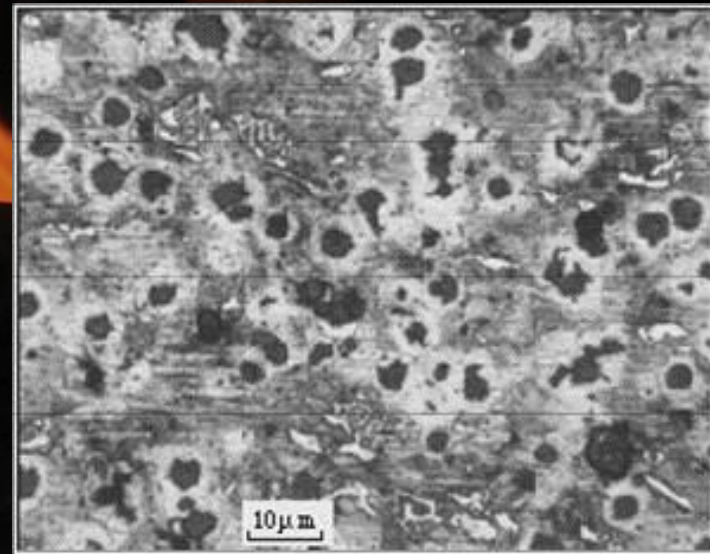

# ESPECTROS Y HORNOS DE INDUCCION



# METALES TIPICOS PARA TROQUELES

ASTM	JIS	DIN	SAE	FORD	GM
A48-30	FC250	GG20	G2500	GG25	
A48-40	FC300	GG30	G3000	GG30	
A48-60		GG40			
Gr-60/40/18	FCD400	GGG40			
Gr-65/45/12	FCD500	GGG50	J434D4512	GGG50	GM245M
Gr-80/55/06	FCD600	GGG60	J434D5506	GGG60	GM246M
Gr-100/70/03	FCD700	GGG70	J434D7003	GGG70L	GM247M
A27Gr-60-30	G4051-S20L	GS45	1020		GM168M
A27Gr-70-36	64051-S30L	GS52	1030		
A27Gr-70-40	64051-S40L	GS60	1040		
			4140	SG7	

# PIEZAS



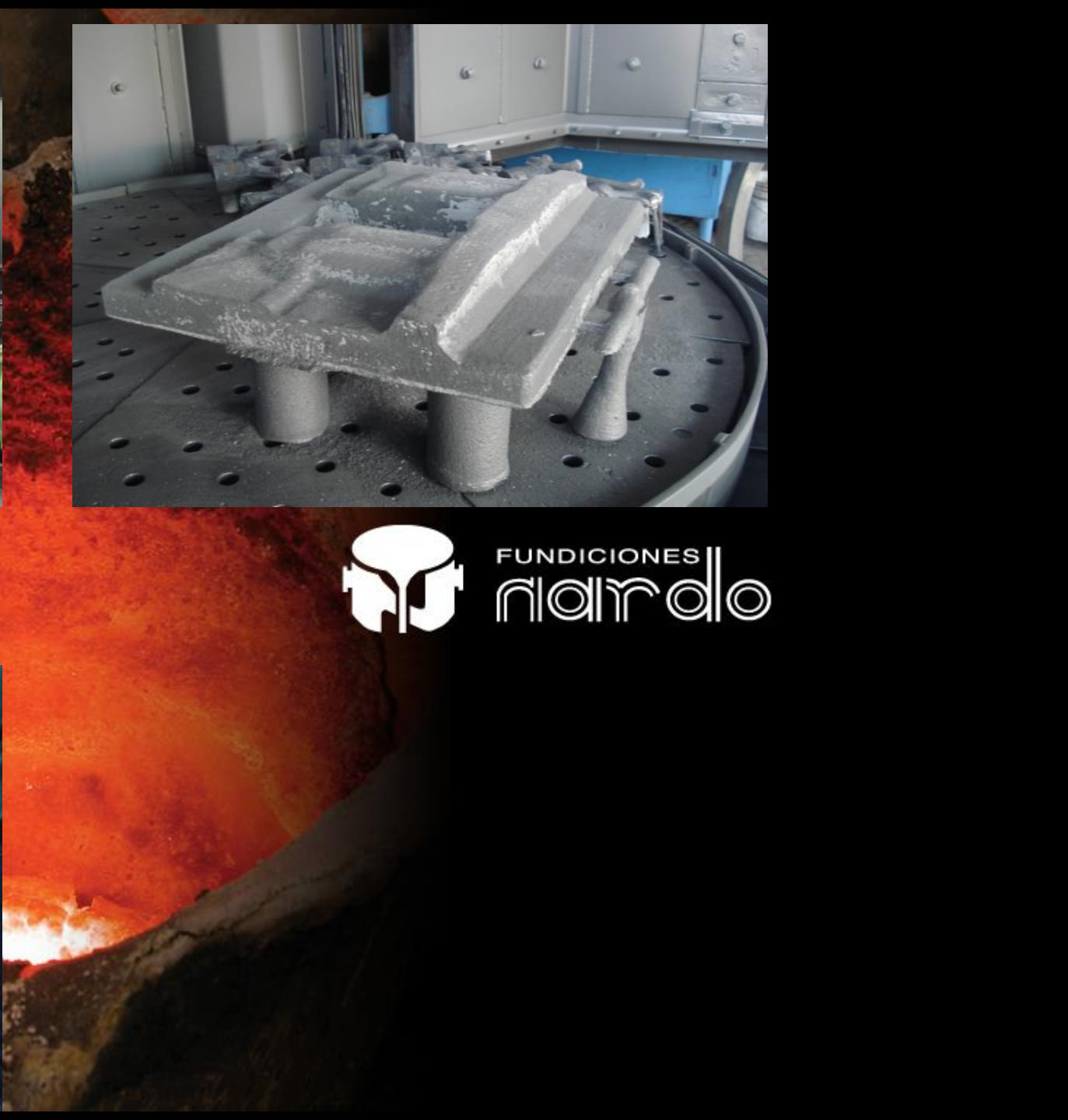
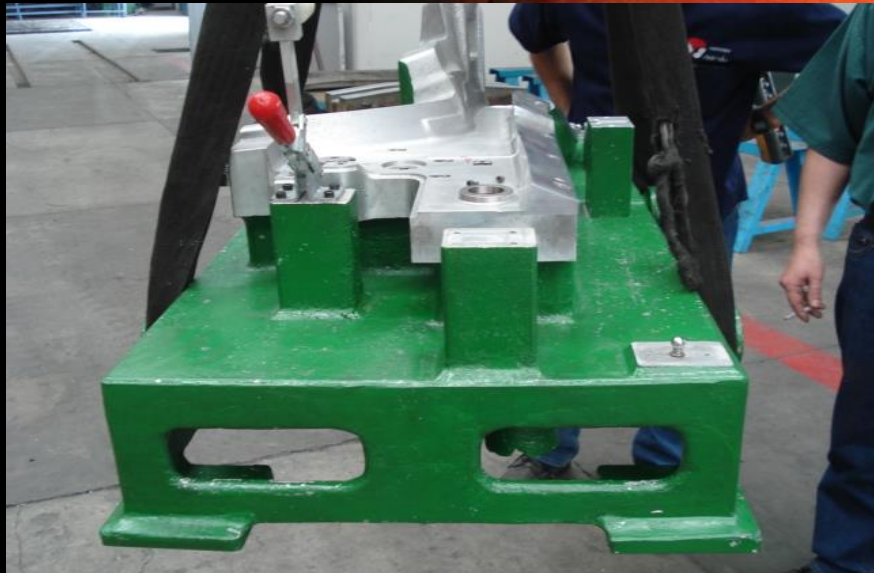



FUNDICIONES  
narro